

ASC325 100-1000 MHz High Power Amplifier

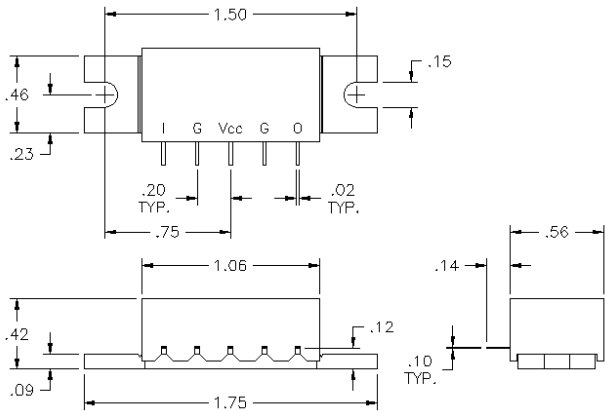

Features: (typical values)

- Low Noise Figure 3.7 dB.
- High Output Power +31.5 dBm.
- High IP3 +47dBm.
- Low Cost
- No external components required

Specifications (Referenced to 50 ohms)

Parameter	Typical Value	Min. Value	Max. Value	Units
Frequency		100	1000	MHz.
Gain	23.0	18.0		dB.
Gain Flatness	±0.3		±0.5	dB.
Gain Var. over temp.	0.7			ΔdB.
Pout @ 1dB. Comp.	+31.5	+30.0		dBm.
Noise Figure	3.7		5.5	dB.
Reverse Isolation	35.0			dB.
IP ₃ (two tone)*	+47.0	+44.0		dBm.
VSWR In/Out	1.7:1		2.0:1	
Supply Req'd	+24/390		+24/450	v./mA.

Min. and max. values are from -40°C to +85°C

*IP₃ is an in band output intercept point @ +17 dBm. Per tone

Maximum Ratings

Storage Temperature -40°C to +85°C
 DC Voltage +26 volts
 RF Input Power +15.0 dBm.
 Case Temperature +95°C

Actual Performance Curves

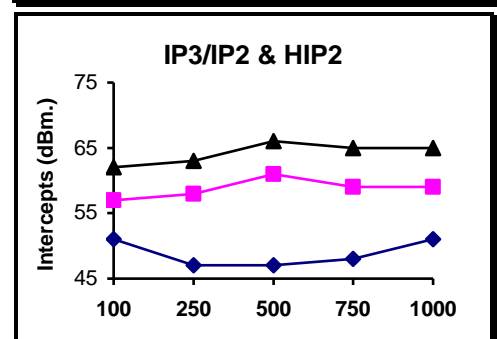
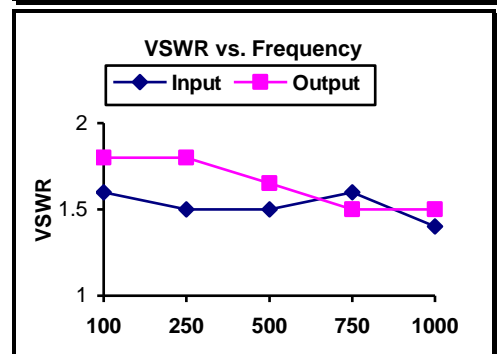
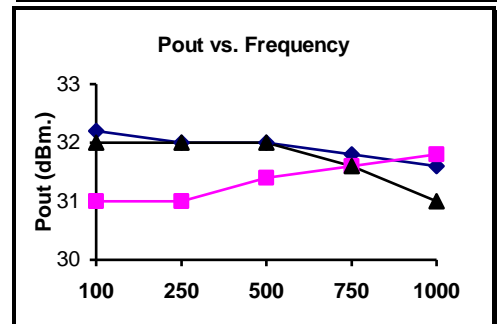
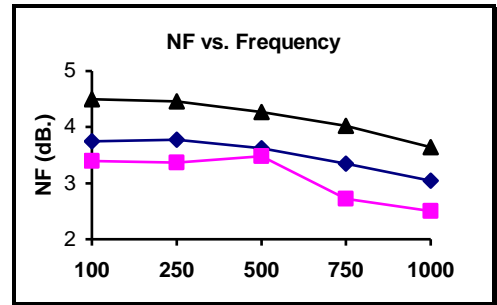
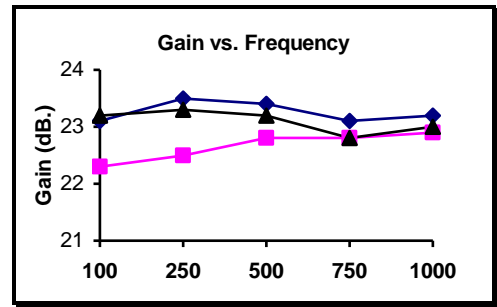

FUNCTIONAL BLOCK DIAGRAM

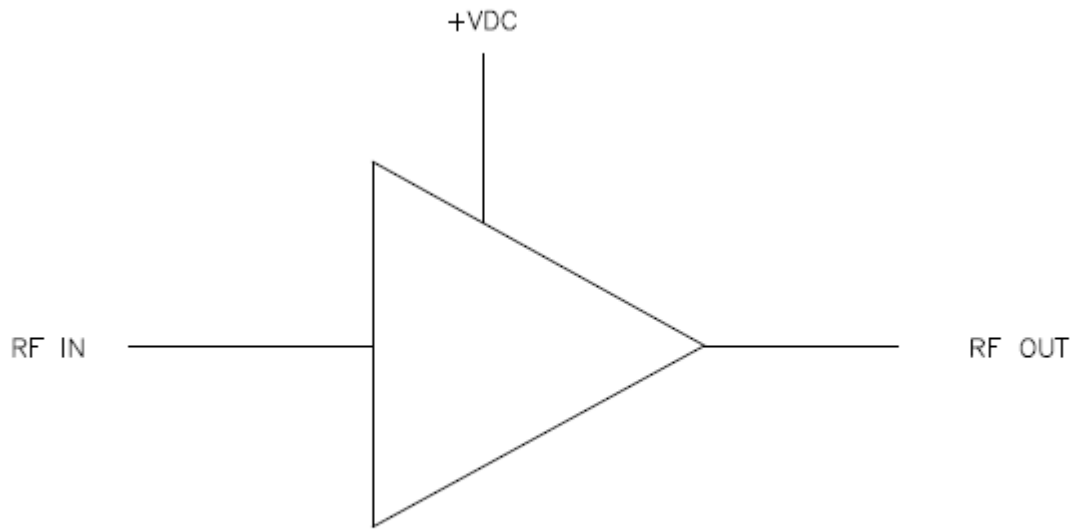

NO EXTERNAL COMPONENT REQUIRED