

Features: (typical values)

- Ultra High Linearity
- Low Noise Figure
- Rugged Construction
- Operation over wide voltage range
- Usable for 50 ohm operation
- Unconditional Stability

**2 – 250 MHz
22dB CATV Ultra-linear
Amplifier**

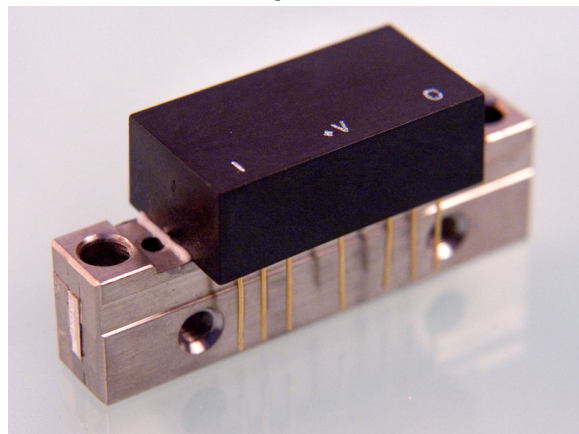

Maximum Ratings

Storage temperature -40°C to +100°C
 DC Operating Voltage +28.0 volts
 RF Input Voltage 40 dBmV max.
 Operating Base Temp. +100°C

Specifications @ Tcase = 30°C (Referenced to 75 ohms)

Parameter	Typical Conditions	Min Value	Max Value	Units
Frequency Range		2	250	MHz.
Power Gain	f = 50MHz.	21.0	23.0	dB.
Cable equivalent slope	f = 2MHz. TO 250MHz.	0	1.0	dB.
Gain Flatness (peak to valley)	f = 2MHz. TO 250MHz.		0.8	dB.
Input/Output Return Loss	f = 5MHz. TO 250MHz.	18		dB.
Input/Output Return Loss	f = 5MHz. TO 250MHz.	16		dB.
Composite Triple Beat (CTB)	79 channels flat, Vo=60dBmV. Measured @ Channel 78		-70	dBc
Cross Modulation (XMOD)	79channels flat, Vo=60dBmV. Measured @ Channel 2		-62	dBc
Composite 2 nd Order (CSO)	79 channels flat, Vo=60dBmV. Measured @ Channel 78		-70	dBc
IP ₃ /IP ₂ 2 tones @ +15dbm per tone	52/86	49/75		dBm.
P1dB	+35	33		dbm
Noise Figure (NF)	2.7 dB		4.0	dB.
Total Current (I _{TOT})	+24V/432mA		470	mA.

Pin Configuration

PIN#	Description
1	Input
2,3,7,8	Ground
5	+V.
9	Output
4, 6	Not used

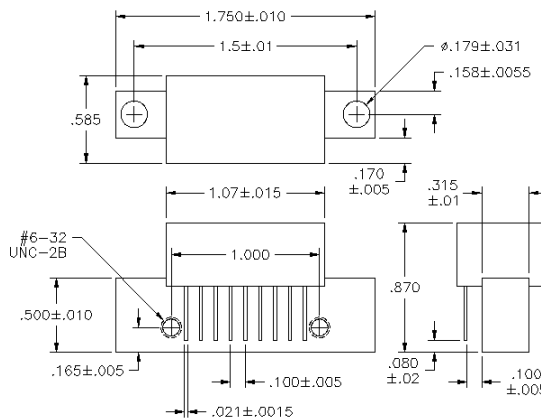

FINAL ELECTRICAL TEST REPORT
RECORD DATA @ +30°C ONLY

TEST (REF 75 OHM) Vdc +24V	LIMITS +30°C	ACTUAL DATA
Power Gain @50 MHz	21.0 dB min 23.0 dB max	22.5 22.7
Cable equivalent slope 40 MHz to 550 MHz	1.5 dB Max	0.1
Gain Flatness (peak to peak) 40 MHz to 550 MHz	0.8 dB max	0.2
Noise Figure @ 550 MHz	4.0 dB max	2.11
DC Current at +24 Vdc	450 mA max	406
P1dB	33.0 dBm Min	>34.0
VSWR In (75 OHM) @40 to 160 MHz @160 to 550 MHz	18 dB Min 16 dB Min	29.0 19.0
VSWR Out (75 OHM) @40 to 160 MHz @160 to 550 MHz	18 dB Min 16 dB Min	21.8 19.5
IP3 @ Pout = +15.0 dBm 1) F(1,2)= 41,42 MHz Fc(40,43 MHz) 2)F(1,2)= 548,549 MHz Fc(547,550) MHz)	+49.0 dBm min	51.0
IP2 @ Pout = +15 dBm 1) (F1-F2) = (550-510) MHz Fc = 40 MHz 2) (F1+F2) = (210+340) MHz Fc = 550 MHz	+65.0 dBm min	79.0
Composite Triple Beat (CTB) 77 channels flat, Vo=44dBmV. Measured @ Channel 78	N/A	N/A
Cross Modulation (XMOD) 77 channels flat, Vo=44dBmV. Measured @ Channel 2	N/A	N/A
Composite 2 nd Order (CSO) 77 channels flat, Vo=44dBmV. Measured @ Channel 78	N/A	N/A
Stability Test for all frequency range where S21 > 0 dB	0 dB max	<0

